

## 电子及工业用玻璃纤维细纱

电子及工业用玻璃纤维细纱适用工艺: 织造, 涂塑, 编织

玻璃纤维电子纱、工业纱系列







## 包装

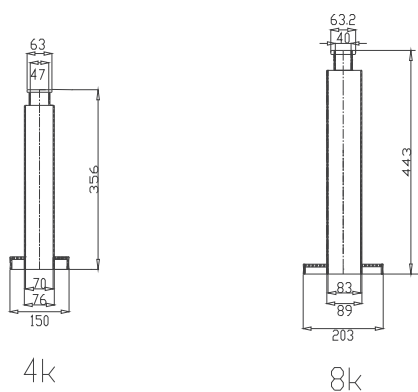

## 托盘型号



